



LOOP-INSULATOR WITH SILICONE COVER

## KULOOP

Our aim at Kummler+Matter Ltd. is to accommodate today's market requirements, so we have redesigned our existing loop insulator. The key benefits of the new KULOOP loop insulators are substantial increases in tensile load and life expectancy as compared to existing

insulators. The new product (article no. D4069-01) can be used as a 1:1 replacement for all our older models. For the international market, we have also developed an extended loop insulator (article no. D4069-02) which implements

the recommendation given in standard EN 50119 for the air gap between metal parts. Both versions have been tested to IEC standard 61109, with successful results.

**+45%**  
max. tensile load

**+40%**  
longer lifetime

# LOOP INSULATOR WITH SILICONE COVER

Article no. D4069-01

Article no. D4069-02

## KUMMLER+MATTER – CONTINUOUS PRODUCT DEVELOPMENT

Yet another development from Kummler+Matter to replace conventional loop insulators with no silicone cover

## CHARACTERISTICS

These insulators have a glass fibre core and fittings made of stainless steel (A4) to enable a precise connection with the shackle. The loop insulator can also be used under unfavourable operating conditions (heavy contamination), and it has a self-cleaning effect. Another benefit: it is less vulnerable to vandalism and impact shocks than its predecessor products.

## APPLICATIONS IN CATENARY SYSTEMS

An insulating element for:

- ✓ Cross-spans / cross-cables
- ✓ Top ties
- ✓ Contact wire suspensions
- ✓ Fixed contact wire terminations
- ✓ Auto-tensioned systems
- ✓ Intermediate insulation in the support structure
- ✓ Section insulation

## GENERAL

- ✓ Insulated fixes terminations for public lighting installations

## INSTALLATION

The loop insulator can also be used with K+M double straps, triangular and square/rectangular plates.

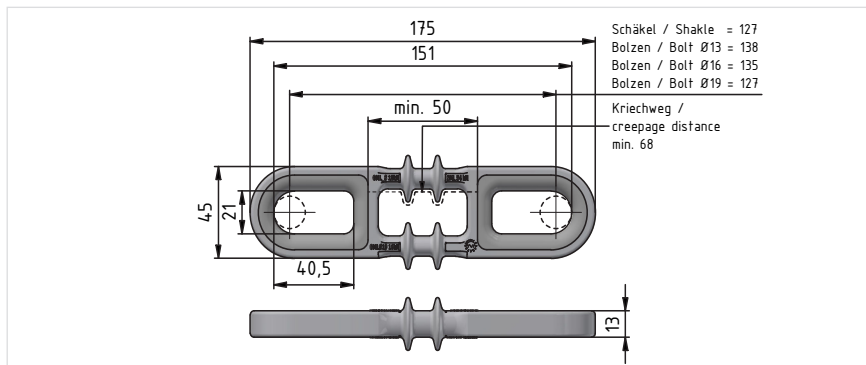

Article no. D4069-01 Air gap between metal parts = 50 mm

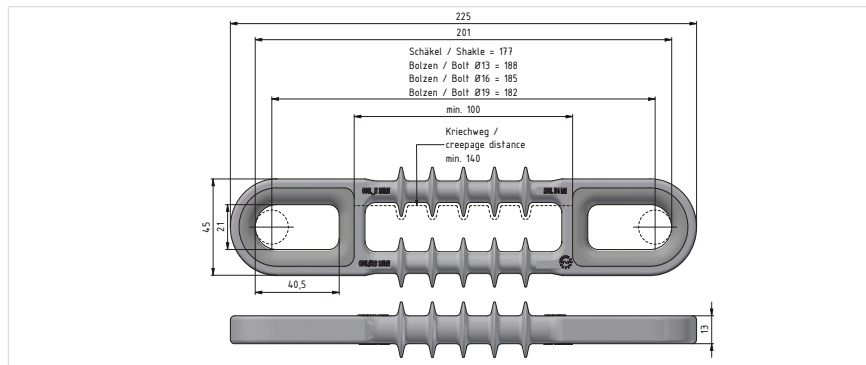

Article no. D4069-02 Air gap between metal parts = 100 mm

## YOUR BENEFITS AT A GLANCE

- ✓ +45% maximum tensile load
- ✓ +40% longer lifetime

- ✓ Stainless steel armatures
- ✓ Versatile applications
- ✓ Can be used with shackle (article no. E0928-01/02)
- ✓ Interchangeable with existing loop insulators

## SPECIFICATIONS

KULOOP D4069-01/02 IN COMBINATION WITH		SML [kN]	OML [kN]
	SHACKLE E0928	54	18
	BOLT Ø 19	48	16
	BOLT Ø 16	45	15
	BOLT Ø 13	42	14

Legend SML = Specified Mechanical Load  
OML = Permissible Operating Load

- ✓ Maximum operating voltage:  
D4069-01 1.5 kV DC  
D4069-02 1.5 kV DC (electrically tested up to 3 kV DC)
- ✓ Weight: ≈ 0.2 kg

## STANDARDS

The loop insulators were developed and successfully tested in compliance with standard EN 50119. The recommended air gap between metal parts is only met by article no. D4069-02 at 1.5 kV DC.

## SPARE PARTS CONCEPT

- ✓ Artikel Nr. D4069-01 Replaces Article no. D2786-01 and Article no. D2864-01
- ✓ Artikel Nr. D4069-02 Replaces: Article no. D2786-02

Kummler+Matter Ltd.  
Rietstrasse 14  
8108 Dällikon  
Switzerland

+41 44 247 47 47  
info@kummlermatter.ch  
kummlermatter.ch



FOR YOUR OVERHEAD CONTACT LINES