

## INSTALLATION-OPTIMISED MULTI-TRACK CANTILEVER WITH FAST-RELEASE WEDGE CONNECTOR



Up to  
-90%  
Installation time during  
blocked periods

## KUMAK

The key benefit of our multi-track cantilever with the fast-release wedge connector is that installation effort is significantly reduced. Thanks to simple, positive-locking plug-in connectors and only a small number of bolted joints, the system is set up

very quickly and easily. The narrow time windows available on site can therefore be utilised more efficiently and costs can be cut to the minimum. The torsion-resistant connection to the mast means that the cantilever does not require an additional wind

stay. The system has been set up for training purposes at Kummler+Matter's premises in Dällikon, and interested visitors are welcome to arrange an appointment to view it.

# CANTILEVER LENGTHS UP TO 15 METRES

## MULTI-TRACK CANTILEVER WITH FAST-RELEASE WEDGE CONNECTOR

Thanks to its slimline design, the system has low susceptibility to wind impact. The high-performance supporting structure also meets visual requirements with its lightweight filigree design.

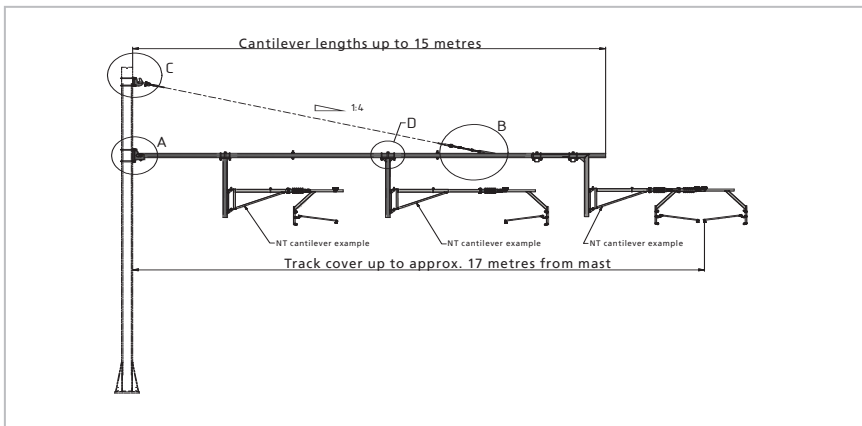

Maximum cantilever lengths

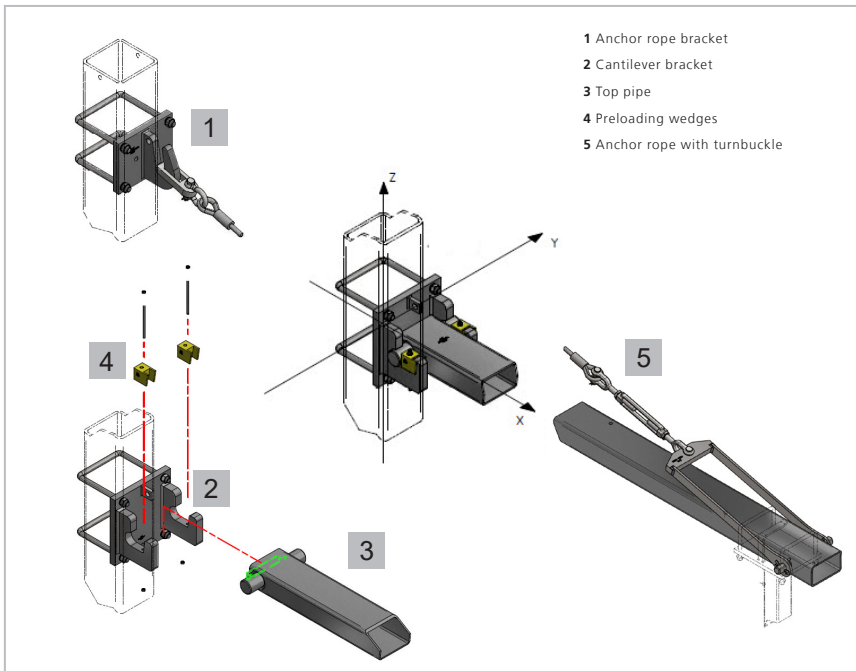

Fixing to the mast is simple thanks to the patented system

### YOUR BENEFITS AT A GLANCE

- ✓ Up to -90% installation time
- ✓ Coverage for up to three operating tracks
- ✓ Optimised utilisation of short blocked periods
- ✓ More efficient installation processes
- ✓ System is suitable for placement by helicopter
- ✓ Suitable for semi-tensioned (ST) and fully compensated (FC) cantilevers
- ✓ No additional wind stay required
- ✓ 100% compatible with various catenary systems (example illustrated with SBB Switzerland NT cantilever)

### SPECIFICATIONS

- ✓ Cantilever length: 5.0–15.0 m
- ✓ Cantilever profile RRW: 240x150x(X) mm
- ✓ Track coverage up to approx. 17 m
- ✓ For mast types:
  - RRW 250x250x16 mm
  - RRW 300x300x16 mm
  - RRW 350x350x16 mm
- ✓ Permitted payload: 1.5 kN/m' plus relocatable single load of Qk: 2 kN (for a base length of 13 m)
- ✓ Permitted horizontal connection torque: Mk: 40.0 kNm

### STANDARDS

- ✓ SN-EN standards for supporting structures
- ✓ RTE 27200
- ✓ EN 50119

### Patent filed

- ✓ Patent number: 19184122.0 - 1205

Kummler+Matter Ltd.  
Rietstrasse 14  
8108 Dällikon  
Switzerland

+41 44 247 47 47  
info@kummlermatter.ch  
kummlermatter.ch



FOR YOUR OVERHEAD CONTACT LINES